

All-Energy 2005

Distribution price control

Martin Crouch
Director, Electricity Distribution
Ofgem

Overview

- Ofgem's role
- Challenges for regulation
- Incentives on distribution companies
- Encouraging innovation
- Next steps

Ofgem's role

- Ofgem's principle objective is "to protect the interests of consumers [present and future] ... wherever appropriate by promoting effective competition"

Challenges for regulation

- Government policy will lead to ...
 - a substantial increase in distributed generation which requires...
 - substantial investment to in connection and network reinforcement (c. £1 bn in 2005-10)

- Old regulatory framework
 - relied on obligations to connect
 - did not provide incentives on distributors to act or to deliver efficient DG-related reinforcement
 - created a “free-rider” issue through deep connection charges

Challenges for regulation

- Regulatory arrangements needed to change to deliver:
 - positive incentives on distributors to respond to users' requirements
 - efficient, economic and co-ordinated network investment
 - focus on “outputs” not “inputs” (access provided rather than poles in the ground)
 - efficient and effective locational signals to network users

- Business as usual not sufficient
 - high potential for innovative solutions
 - will distributors deliver?

An integrated approach

- Distribution Price Control Review
 - incentives on distribution companies to connect and utilise DG efficiently; and
 - Registered Power Zones and Innovation Funding

- Structure of Distribution Charges
 - moving from deep to shallower connection charges
 - introducing generator use of system charges

- These must work together as a package to encourage efficient, co-ordinated solutions

Incentive mechanisms

- Distributors are better placed than Ofgem to assess likely activity and implied investment
- Level of investment required is uncertain – regulation needs to be flexible to accommodate new information
- Mechanism developed
 - high level of pass-through (80%); plus
 - £1.50/kW per year (£2 in SSE-Hydro) plus £1/kW for O&M
 - cap and collar on distributors' returns to protect against uncertainty
- Distributors benefit if they deliver capacity where it is needed and when it is needed

The innovation process

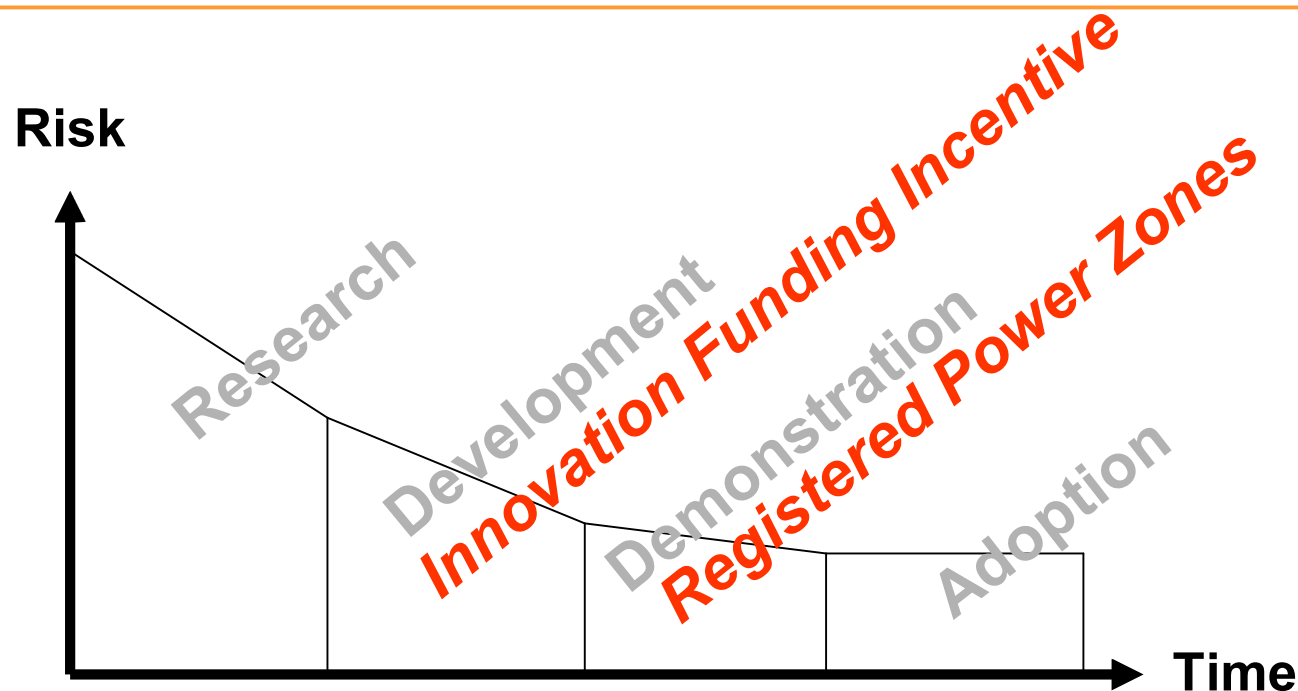

IFI & RPZ – Targeted incentives for network companies

Innovation Funding Incentive

- Expenditure is allowed on a 'use it or lose it' basis up to 0.5% of revenue (£1-2m per company)
- The companies fund a proportion of each project (av. 20%)
- Annual, open, reporting of projects to promote best practices
- Started October 2004

Registered Power Zones

- Specifically aimed at technical innovation for DG connection
- Enhanced financial incentive (3x main DG incentive) provides a balance to innovation risks
- Open reporting of RPZ projects to promote best practices

A view of today

Today's networks
Unidirectional power flows

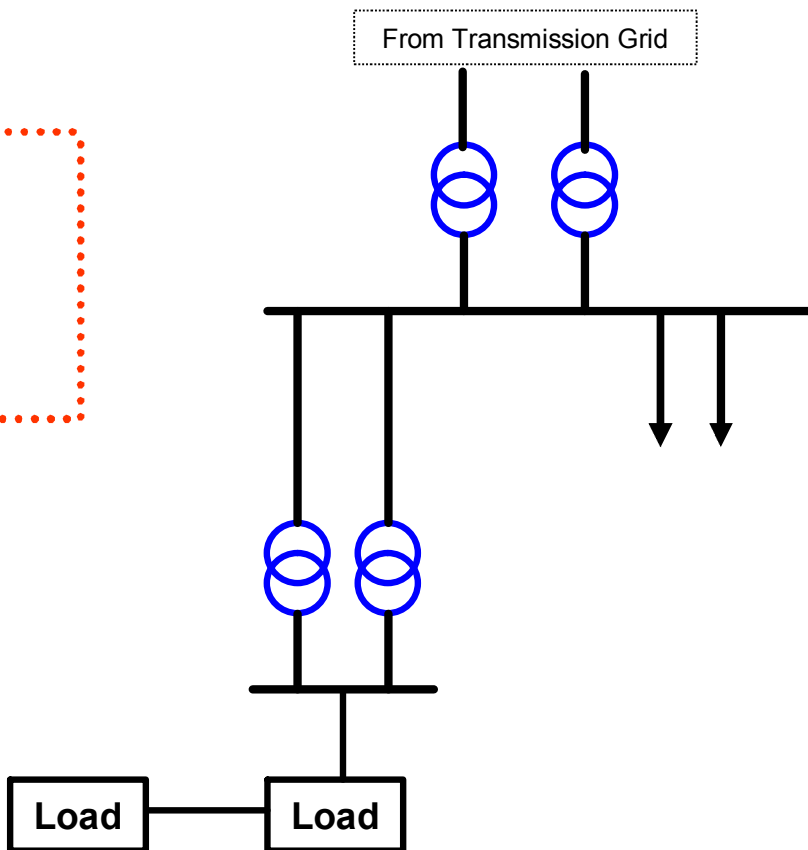

Boundary flow

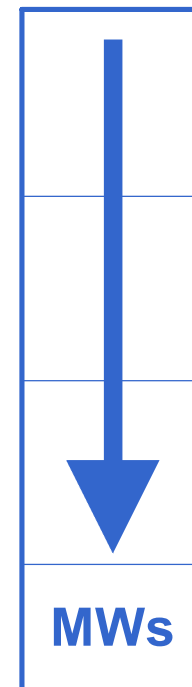

Perhaps a 'Registered Power Zone' ?

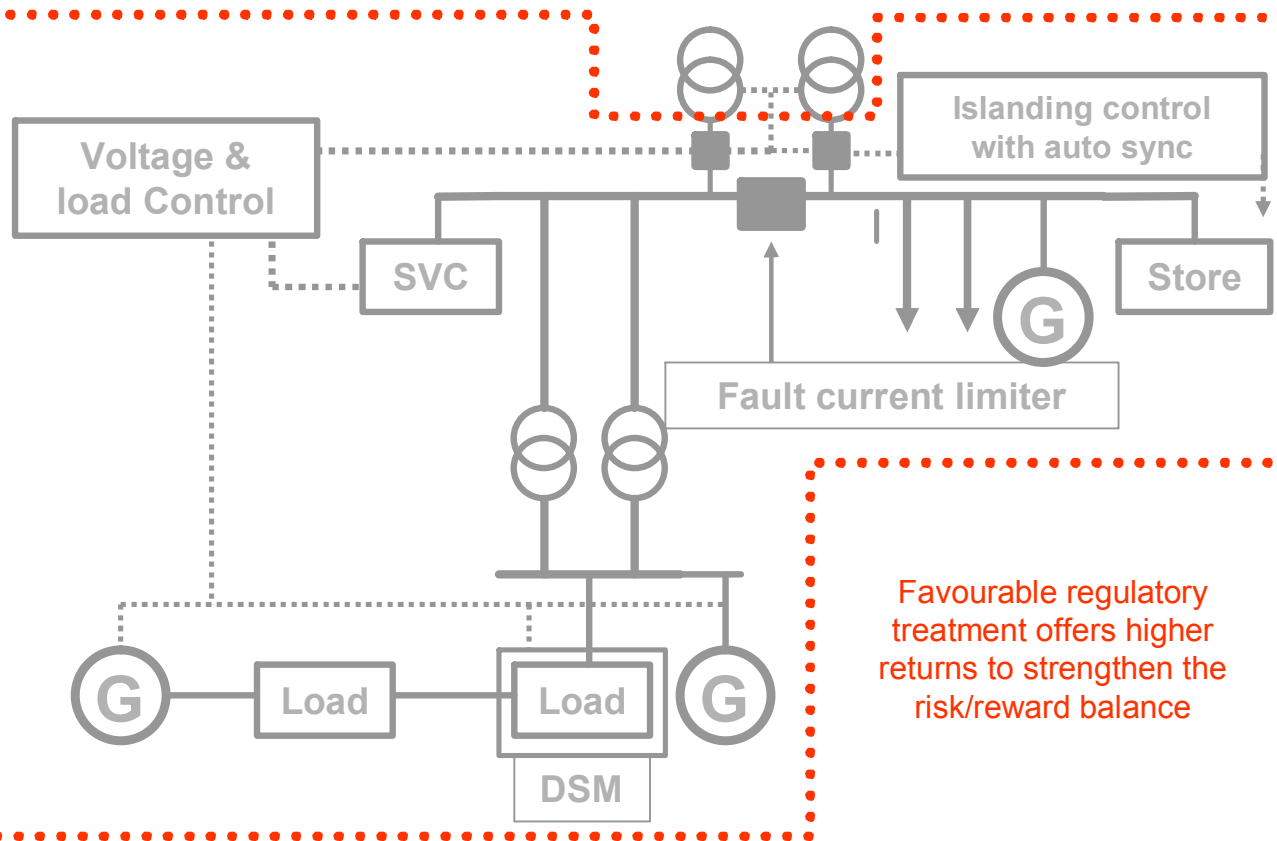

- ✓ Special regulatory treatment
- ✓ Suited to technology demonstrator projects
- ✓ Benefits of “badging” as a form of endorsement
- ✓ May attract external grant funding and Regional Development joint projects
- ✓ Signals a generation-friendly network to developers
- ✓ ‘Club Rules’ protect customers and ensure information sharing

In Summary - Key Messages

- ❖ Many more generators connecting to distribution networks reverses the trend of 50 years. Engineering innovation is needed to contain the costs and address the challenges.
- ❖ Ofgem has introduced new financial incentives for distribution companies to encourage DG connection and network innovation.

Next steps

- ✓ IFI expenditure eligible from October 2004
- ✓ Distribution price control proposals implemented 1 April 2005
- ✓ Shallower connection charges and GDUoS introduced

- Consultation underway on network charges to distributed generators – aiming to move towards robust model of network costs and benefits
- First annual IFI reports to be published this summer

- Monitoring DG connection activity and incentives
- Formal review of IFI/RPZ in 2007



***Your Questions and Comments
will be welcomed***